

Filamatic

Your Specialist in Liquid Filling

Filamatic, a division of National Instrument, LLC, has been serving the pharmaceutical, biotech, healthcare, contract packaging, cosmetic, chemical specialty and food industries since 1950. We provide a wide range of equipment that can be customized to suit your unique application and budget.

We meet the ever changing demands of our customers by providing high performance, reliable liquid filling systems that deliver value, accuracy, faster changeover, and low total cost of ownership year after year. Today as always, the heart of our business lies in the strong and lasting relationships we enjoy with our customers.



Specialists in Liquid Filling Systems

4119 Fordleigh Road
Baltimore, Maryland 21215 USA
Phone 866-258-1914 or 410-764-0900
sales@filamatic.com
www.filamatic.com

Monobloc Fill/Finish Packaging Systems

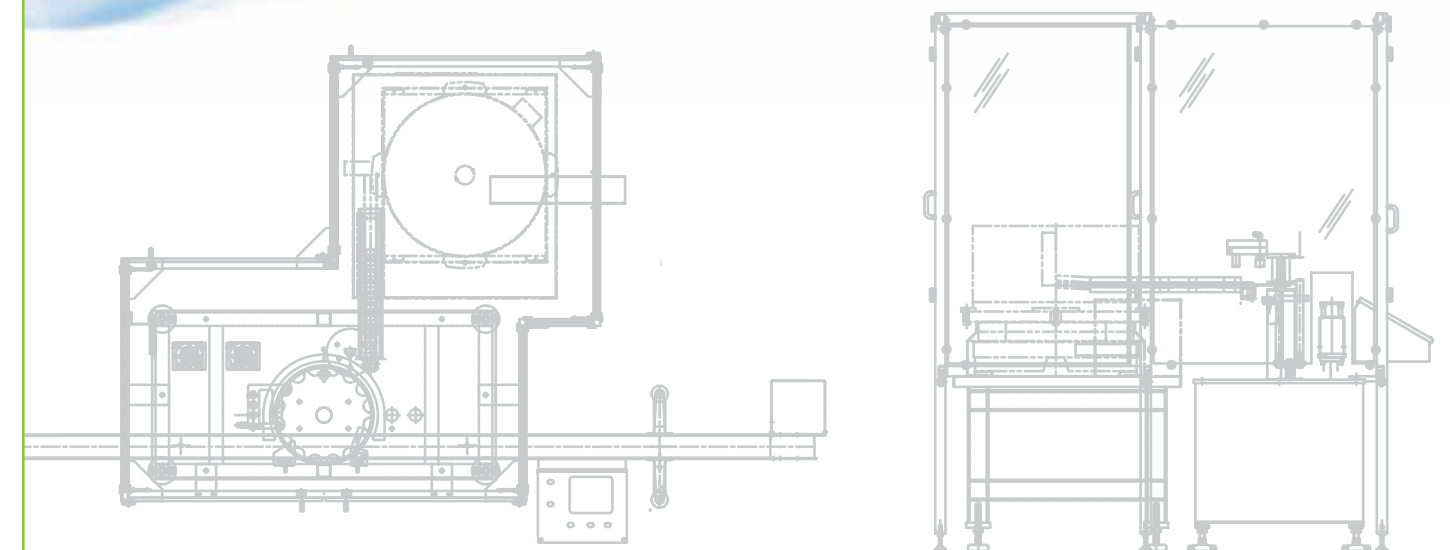

Monobloc Features

Countless Capabilities

The Monobloc performs a wide range of tasks such as sorting, feeding, filling, plugging, stoppering, crimping, capping, labeling, and accumulating in a compact footprint. This state-of-the-art liquid packaging system is capable of filling water-thin to viscous products into a variety of container shapes and sizes.

- 💧 A variety of liquid metering systems are available to provide a fill volume range of 0.5 ml to 500 ml per cycle
- 💧 User friendly HMI touch screen with menu-driven programs that electronically adjust operating parameters for quick and easy tool-less changeovers
- 💧 Proven servo motor driven technology
- 💧 Optional HEPA filtration system



Versatility, Precision, and Accuracy

Customized Fill/Finish Packaging System

Filamatic offers several models that can be customized to suit your unique application. The versatility, precision, and accuracy of the Monobloc make it ideal for:

- 💧 Unique container configurations
- 💧 Multiple fill volumes and container sizes
- 💧 Aseptic filling requirements
- 💧 Increased automation and efficiency
- 💧 Research and Development
- 💧 Compact production spaces

Built To Order, Built To Last



Mini-Monobloc
Ideal for small
productions runs



MNB 2000
A complete fill/finish
packaging system



MNB XT High Speed
A faster version of the
MNB 2000

Service and Support

Before, During, and After Sale

Filamatic will partner with you before, during, and after the sale. Our experienced and innovative engineering team will identify the ideal liquid filling solution for your unique application. Our project management team will provide you with one point of contact from start to finish. Our superior technical and customer service teams will provide excellent support and service long after the sale.



Proudly built in the U.S.A.